

CARES Technical Approval Report TA1-B&C 5036

Issue 6



HRC 400 Series Rebar Couplers

Assessment of the
HRC 410/420
and HRC 410/490
Welded Coupler and
Quality System for
Production



TECHNICAL
APPROVAL
5036



002

Product

HRC 410/420
and HRC 410/490
Welded Couplers
for reinforcing steel

Product approval held by:

HRC Europe AS
Lierstranda 107
Lier
N-3400
Norway
Tel: +47 32 24 04 70
www.hrc-europe.com

1 Product Summary

HRC 410/420 and HRC 410/490 welded couplers in the size range 16mm - 32mm are for the mechanical connection of deformed high yield carbon steel bars for the reinforcement of concrete complying with the requirements of BS4449 Grade B500C.

1.1 Scope of Application

HRC 410/420 welded couplers in the size range 16mm - 32mm and 32mm HRC 410/490 welded position couplers have been evaluated for use as follows:

- a) TA1-B: Eurocode 2 and BS 8110 for static applications in compression and tension with Grade B500C reinforcement.
- b) TA1-C: Sellafeld Type A couplers in tension and compression with grade B500C reinforcement.

1.2 Design Considerations

BS 8110 Clause 3.12.8.9 Laps and Joints states "Connections transferring stress may be lapped, welded or joined with mechanical devices. They should be placed, if possible, away from points of high stress and should preferably be staggered". However, BS 8110 Clause 3.12.8.16.2 Bars in tension states "The only acceptable form of full-strength butt joint for a bar in tension comprises a mechanical coupler" satisfying specified slip and tensile strength criteria.



Eurocode 2, Clause 8.7 Laps and mechanical couplers 8.7.1 General (1)P "Forces are transmitted from one bar to another by:

- lapping of bars, with or without bends or hooks;
- welding;
- mechanical devices assuring load transfer in tension-compression or in compression only."

Clause 8.8 Additional rules for large diameter bars goes on to state that "Splitting forces are higher and dowel action is greater with the use of large diameter bars. Such bars should be anchored with mechanical devices."

The specified cover for fire resistance and durability should be provided to the coupler sleeve. All couplers have been designed with controlled mechanical properties to be compatible with reinforcing bars complying with reinforcement of the relevant Grade in accordance with BS4449.

1.3 Conclusion

It is the opinion of CARES that HRC 410/420 welded couplers in the size range 16mm - 32mm and 32mm HRC 410/490 welded position couplers are satisfactory for use within the limits stated in paragraph 1.1 when applied and used in accordance with the manufacturer's instructions and the requirements of this certificate.

Lee Brankley

L. Brankley
Chief Executive Officer

January 2020



2 Technical Specification

2.1 General

The function of HRC 410/420 welded couplers and HRC 410/490 welded position couplers is to connect deformed steel reinforcing bars complying with BS 4449 Grade B500C as appropriate and thereby to create structural continuity of the reinforcing system.

2.2 HRC 410/420 welded standard coupler

The HRC 400 rebar coupler system consists of separately machined coupler parts with self locking taper threads. The components are welded to the corresponding ends of the reinforcement bars. The complete mechanical splice is designed to have a tensile strength higher than 700 MPa, well above the actual tensile strength of most reinforcing bars. This enables the use of the full ductility of the actual reinforcing steel heat.

The system consists of the HRC 410/420 standard couplers.

Standard Coupler

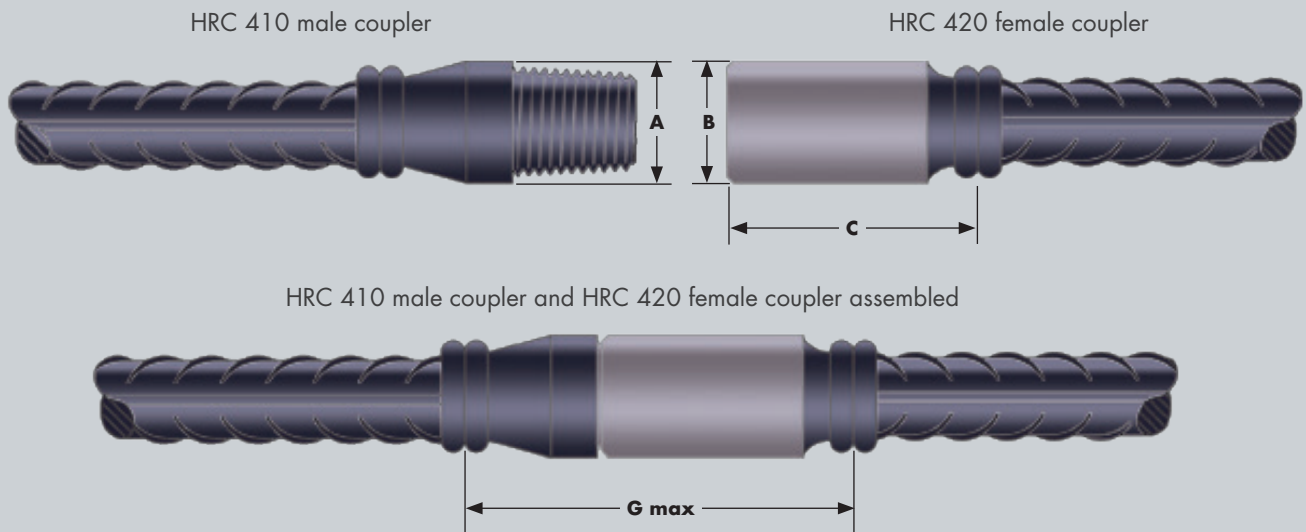

Designation	Nominal diameter of reinforcement bar	Ultimate tensile strength of coupler	Sleeve and thread dimensions					Tension and Compression	
	Ø mm		A mm	B mm	C mm	G max mm	Torque Nm	TA1-B B500C	TA1-C B500C
HRC400	16	>850	28	28	50	76	200	✓	✓
	20	>850	35	35	55	85	200	✓	✓
	25	>850	35	42	76	113	270	✓	✓
	32	>850	45	55	90	135	270	✓	✓
HRC400C	32	>750	45	45	90	130	200	✓	✓

Table 1

2.3 HRC 410/490 welded positional coupler

The system consists of the HRC 410 male coupler, HRC 490 sleeve and locknut which allows the mechanical splice to be established without turning a rebar and to bridge small distances.

Positional Coupler with length adjustment

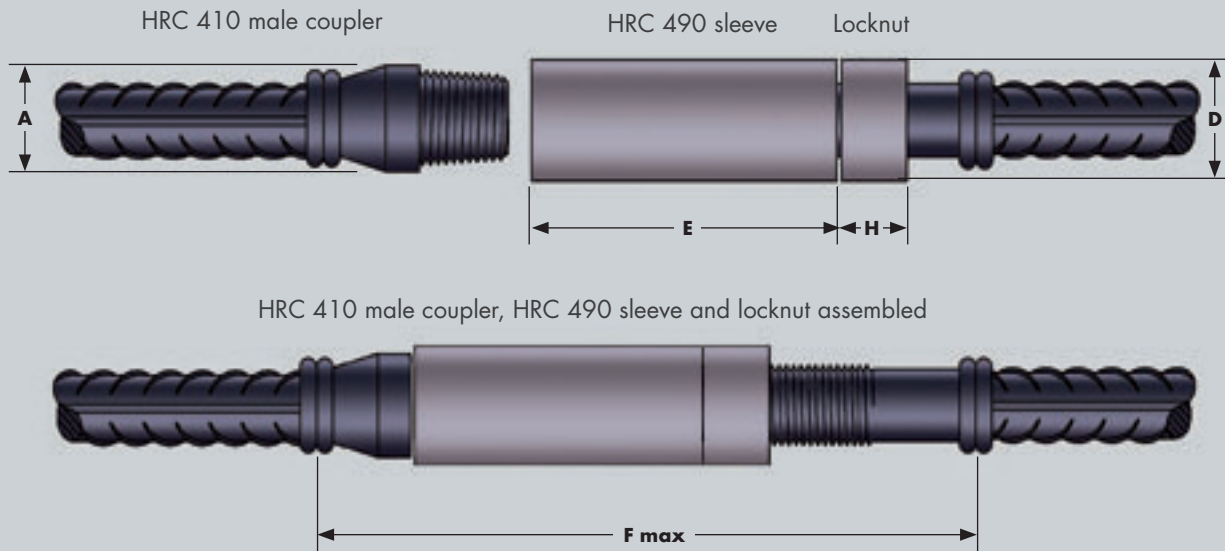

Nominal diameter of reinforcement bar	Sleeve, thread and locknut dimensions						Tension and Compression	
	\emptyset mm	A mm	D mm	E mm	H mm	F max mm	Torque Nm	TA1-B
32	45	55	157	20	330	270	✓	✓

Table 2

Electronic Copy www.ukcares.com



3 Product Performance and Characteristics

Full destructive tests have been carried out to demonstrate compliance with the performance requirements defined in CARES Appendix TA1-B and TA1-C when used with reinforcing steel BS4449 Grade B500C as appropriate:

CARES APPENDIX TA1-B strength requirements

- Permanent deformation is less than 0.10mm after loading to $0.65f_y$ in tension and compression with BS4449 Grade B500C reinforcement.
- 99% characteristic tensile strength is greater than 575MPa with B500C reinforcement.

CARES APPENDIX TA1-C strength requirements

- Permanent deformation is less than 0.10mm after loading to $0.65f_y$ in tension for grade B500C reinforcement.
- Tensile strength $\geq 1.15, \leq 1.35 \times$ Actual yield strength ($f_{y, act}$) for B500C reinforcing steel including:
 - low cycle fatigue: 100 cycles @ 5%-90% f_y
 - and cold soak at -7°C for 24 hours
 - and a bar break mode of failure

4 Installation

HRC 400 Series reinforcement couplers shall be installed according to construction drawings for the works. The couplers shall be used as supplied by the manufacturer, without any modification or exchange of components.

In the case of customer bent bars the distance between the start of the bend and the friction weld shall be no less than two times the nominal bar diameter.



4.1 HRC 410/420 Standard Coupler

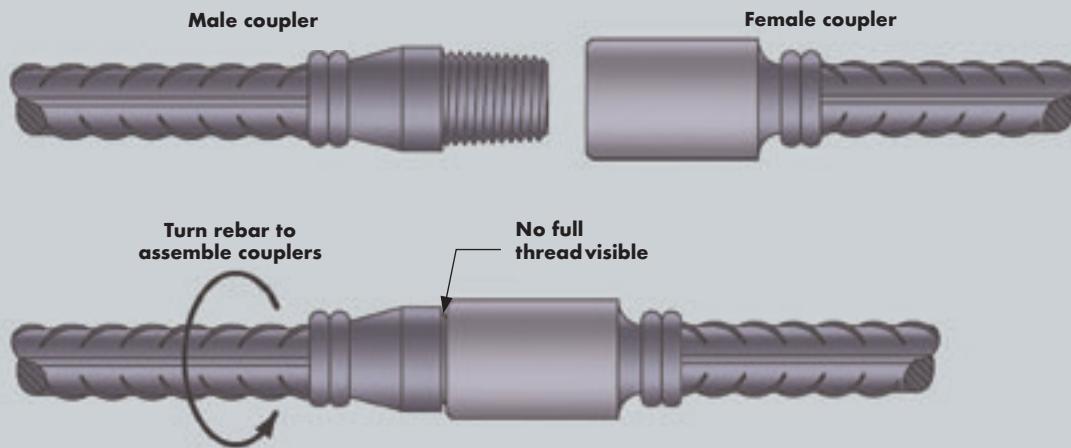

- Remove plastic-plug/cap
- Check for damage / remove dirt etc.
- Screw male and female couplers firmly together by hand
- Visual control: no full thread visible
- Apply torque as indicated in table

Designation	HRC 400				HRC 400C
Nominal diameter of reinforcement bar (mm)	16	20	25	32	32
Torque (Nm)	200	200	270	270	200

Table 3



4.2 HRC 410/490 Positional Coupler

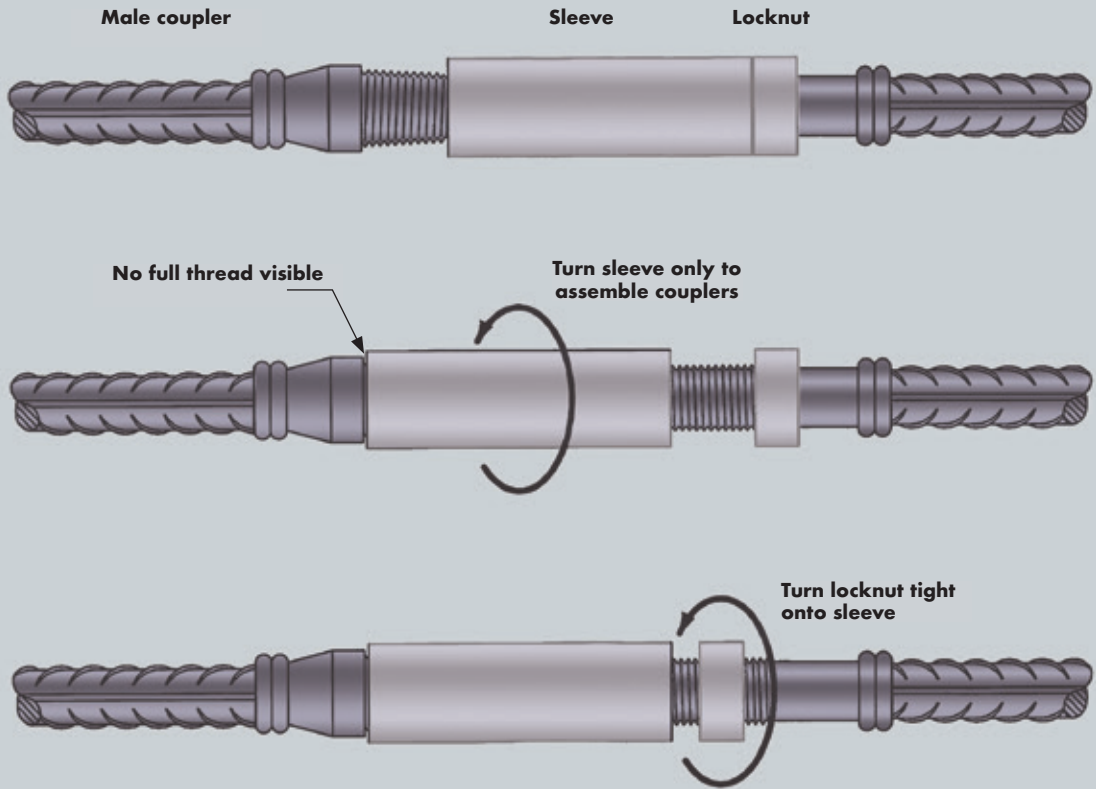

- Make sure sleeve is positioned as far back onto the straight threaded bolt as possible
- Remove plastic-plug/cap
- Check for damage and remove dirt etc.
- Neither rebar needs to be rotated during installation
- Position sleeve at male coupler end (see illustration above)
- Turn sleeve onto taper threaded end
- Make sure all threads are engaged on tapered end
- Visual control: no full thread visible on tapered end
- Apply torque as indicated in table
- Turn lock nut firmly onto sleeve, apply torque

Nominal diameter of reinforcement bar (mm)	32
Torque (Nm)	270

Table 4

5 Safety Considerations

The HRC 400 coupler system is produced by trained personnel, who have the necessary knowledge about safety procedures and measurements.

The coupler components are delivered to the building site ready attached to the rebar. Therefore the usual safety precautions for handling reinforcing steel bars are applicable, as wearing gloves and other relevant safety equipment depending on the actual specific operation.

6 Product Testing and Evaluation

HRC 410/420 welded couplers and HRC 410/490 welded position couplers have been tested to satisfy the requirements of CARES Appendix TA1-B, and TA1-C for Couplers with reinforcing bars to BS4449 Grade B500C.

The testing comprised the following elements:

- Tensile Strength
- Permanent deformation in tension and compression
- Low cycle fatigue

7 Quality Assurance

HRC 410/420 welded couplers and HRC 410/490 welded position couplers are produced under an ISO9001 quality management system certified by CARES. The quality management system scheme monitors the production of the couplers and ensures that materials and geometry remain within the limits of this technical approval.

The products are also subject to a programme of periodic testing.



8 Building Regulations

8.1 The Building Regulations (England and Wales)

Structure, Approved Document A

HRC 400 Series couplers, when used in EC2 based designs using the data contained within this technical approval, satisfy the relevant requirements of The Building Regulations (England and Wales), Approved Document A.

Materials and Workmanship, Approved Document

This technical approval gives assurance that the HRC 400 Series couplers comply with the material requirements of EC2.

8.2 The Building Regulations (Northern Ireland)

Materials and Workmanship

This technical approval gives assurance that HRC 400 Series couplers comply with the material requirements of EC2 by virtue of regulation 23, *Deemed to satisfy provisions regarding the fitness of materials and workmanship*.

8.3 The Building Standards (Scotland)

Fitness of Materials

This technical approval gives assurance that HRC 400 Series couplers comply with the material requirements of EC2 by virtue of *Clause 0.8*.

Structure

HRC 400 Series couplers, when used in EC2 based designs using the data contained within this technical approval, satisfy the requirements of *The Building Standards (Scotland) Clause 1*.

9 References

- BS 4449: 2005: Steel for the reinforcement of concrete - Weldable reinforcing steel - Bar, coil and decoiled product - Specification.
- BS EN 1992-1-1:2004 Eurocode 2 Design of concrete structures - General rules for buildings.
- BS EN ISO 9001: Quality management systems - Requirements.
- CARES Appendix TA1-B; Quality and Operations Schedule for the Technical Approval of Couplers for Reinforcing Steel and Reinforcement Anchors For BS8110 and EN1992-1-1 Applications for Static Loading in Tension or Tension and Compression.
- CARES Appendix TA1-C: Quality and Operations Schedule for the Technical Approval of Tension or Tension- compression Couplers for Reinforcing Steel and Reinforcement Anchors for Sellafield Standard Applications.
- Sellafield Engineering Standard ES_0_3110_2 - Issue1 Mechanical Splices and Anchors to Reinforcement for Concrete Part 2 – Manufacturing, Installation and Construction Requirements.



10 Conditions

1. The quality of the materials and method of manufacture have been examined by CARES and found to be satisfactory. This technical approval will remain valid providing that:
 - a. The product design and specification are unchanged.
 - b. The materials, method of manufacture and location are unchanged.
 - c. The manufacturer complies with CARES regulations for technical approvals.
 - d. The manufacturer holds a valid CARES Certificate of Product Assessment.
 - e. The product is installed and used as described in this report.
2. CARES make no representation as to the presence or absence of patent rights subsisting in the product and/or the legal right of HRC Europe AS to market the product.
3. Any references to standards, codes or legislation are those which are in force at the date of this certificate.
4. Any recommendations relating to the safe use of this product are the minimum standards required when the product is used. These requirements do not purport to satisfy the requirements of the Health and Safety at Work act 1974 or any other relevant safety legislation.
5. CARES does not accept any responsibility for any loss or injury arising as a direct or indirect result of the use of this product.
6. This Technical Approval Report should be read in conjunction with CARES Certificate of Product Assessment No 5036. Confirmation that this technical approval is current can be obtained from UK CARES.



Electronic Copy www.ukcares.com



UK CARES

Pembroke House
21 Pembroke Road
Sevenoaks
Kent TN13 1XR

Phone: +44(0)1732 450000
E-mail: general@ukcares.com
URL: www.ukcares.com

**Independent Product Assessments
for the Construction Industry**

Copyright UK CARES ©